

STANDARD CONSTRUCTION

- FRAME:** 18-GA. galvanized steel, channel or flanged type.
- BLADE:** 18-GA. galvanized steel. Blades approximately 3" on centers.
- SCREEN:** (when indicated)
1/2" sq. mesh, 19-GA. galvanized steel, .041".
- CONSTRUCTION:** Riveted and/or welded for maximum service.

OPTIONS

- Frames and Blades of other gauges
- Other materials - Stainless steel, Copper, Aluminum, etc.
- Finishes - Enamels, Epoxies, etc.
- Screens - Insect screen 1/4" aluminum mesh,
 - or- 1/2" flattened aluminum, .051",
 - or- 1/4" sq. mesh, 18-GA galvanized steel, .047",
 - or- 1/2" sq. mesh, 18-GA stainless steel, .047",
- Others available.

NOTES

1. Nominal deductions will be made to the opening size given.
2. Approximate shipping weight is 10 lbs./sq.ft.

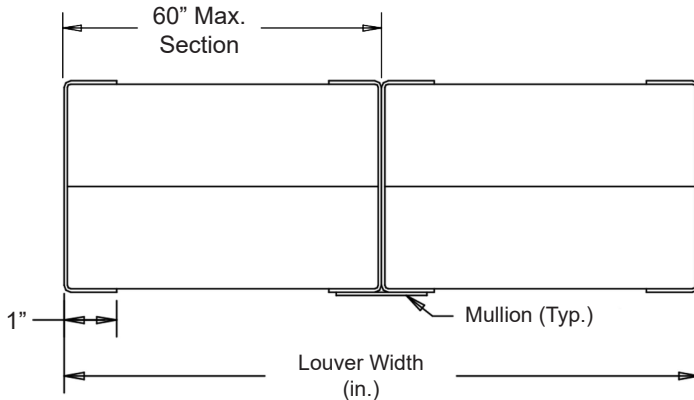
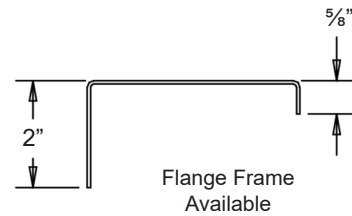
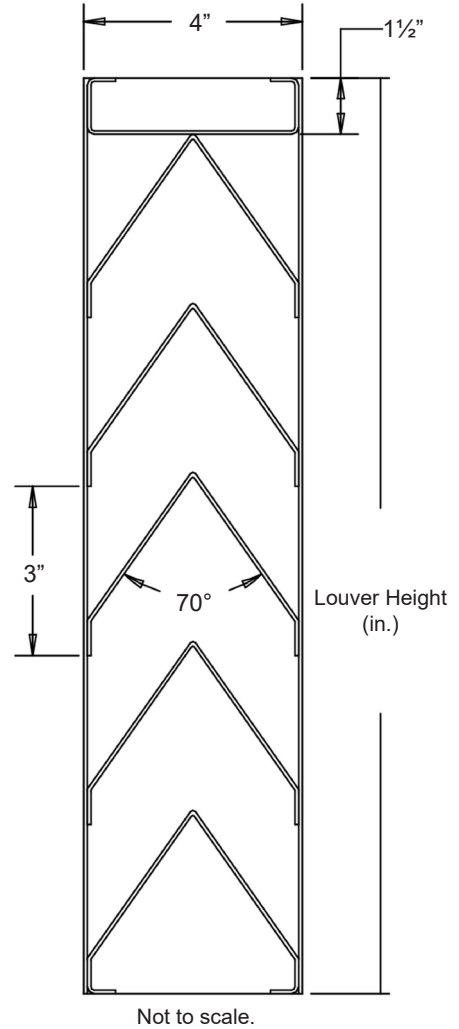

Item #	Qty	Width	Height	Width	Height	Mullion	Type	Location	Union Made
		Opening Size		Louver Size			Screens		
Arch. / Eng. :		EDR:		ECN:		Job:			
Contractor:		Date:		DWN:		DWG:			
Project:									

In the interest of product development, Louvers & Dampers reserves the right to make changes without notice.